

DASH NO.	TUBE SIZE O.D.	THREAD SIZE	TAP DRILL SIZE	Ø A	Ø B	Ø C	D MIN.	E	Ø F MIN.	R
2	1/8	5/16-24 UNF-3B	.272	.059-.065	.313-.333	.192-.212	.252	.325-.345	.672	.09375
3	3/16	3/8-24 UNF-3B	.332	.122-.128	.375-.395	.255-.275	.283	.356-.376	.750	.125
4	1/4	7/16-20 UNF-3B	.391	.169-.175	.438-.458	.310-.330	.332	.422-.442	.828	.15625
5	5/16	1/2-20 UNF-3B	.453	.231-.237	.500-.520	.372-.392	.332	.422-.442	.906	.1875
6	3/8	9/16-18 UNF-3B	.516	.293-.301	.562-.582	.431-.451	.330	.431-.451	.969	.21875
8	1/2	3/4-16 UNF-3B	.688	.387-.395	.750-.770	.609-.629	.371	.486-.506	1.188	.3125
10	5/8	7/8-14 UNF-3B	.813	.481-.488	.875-.895	.722-.742	.453	.586-.606	1.344	.375
12	3/4	1-1/16-12 UNF-3B	.984	.605-.613	1.062-1.082	.899-.919	.501	.658-.678	1.625	.500
16	1	1-5/16-12 UNF-3B	1.219	.839-.851	1.312-1.332	1.148-1.168	.548	.705-.725	1.910	.5625
20	1-1/4	1-5/8-12 UNF-3B	1.500	1.074-1.086	1.625-1.645	1.458-1.478	.544	.701-.721	2.270	.750
24	1-1/2	1-7/8-12 UNF-3B	1.813	1.308-1.320	1.875-1.895	1.710-1.730	.658	.815-.835	2.560	.875
28	1-3/4	2-1/4-12 UNF-3B	2.188	1.543-1.557	2.250-2.270	2.085-2.105	.710	.867-.887	3.010	1.000
32	2	2-1/2-12 UNF-3B	2.438	1.777-1.791	2.500-2.520	2.333-2.353	.825	.982-1.002	3.480	1.1875
40	2-1/2	3-12 UNF-3B	2.875	2.277-2.291	3.000-3.020	2.729-2.749	.670	.827-.847	3.900	1.375
48	3	3-1/2-12 UNF-3B	3.375	2.777-2.791	3.500-3.520	3.229-3.249	.748	.905-.925	4.500	1.625

Modify Cutter Diameter as needed.

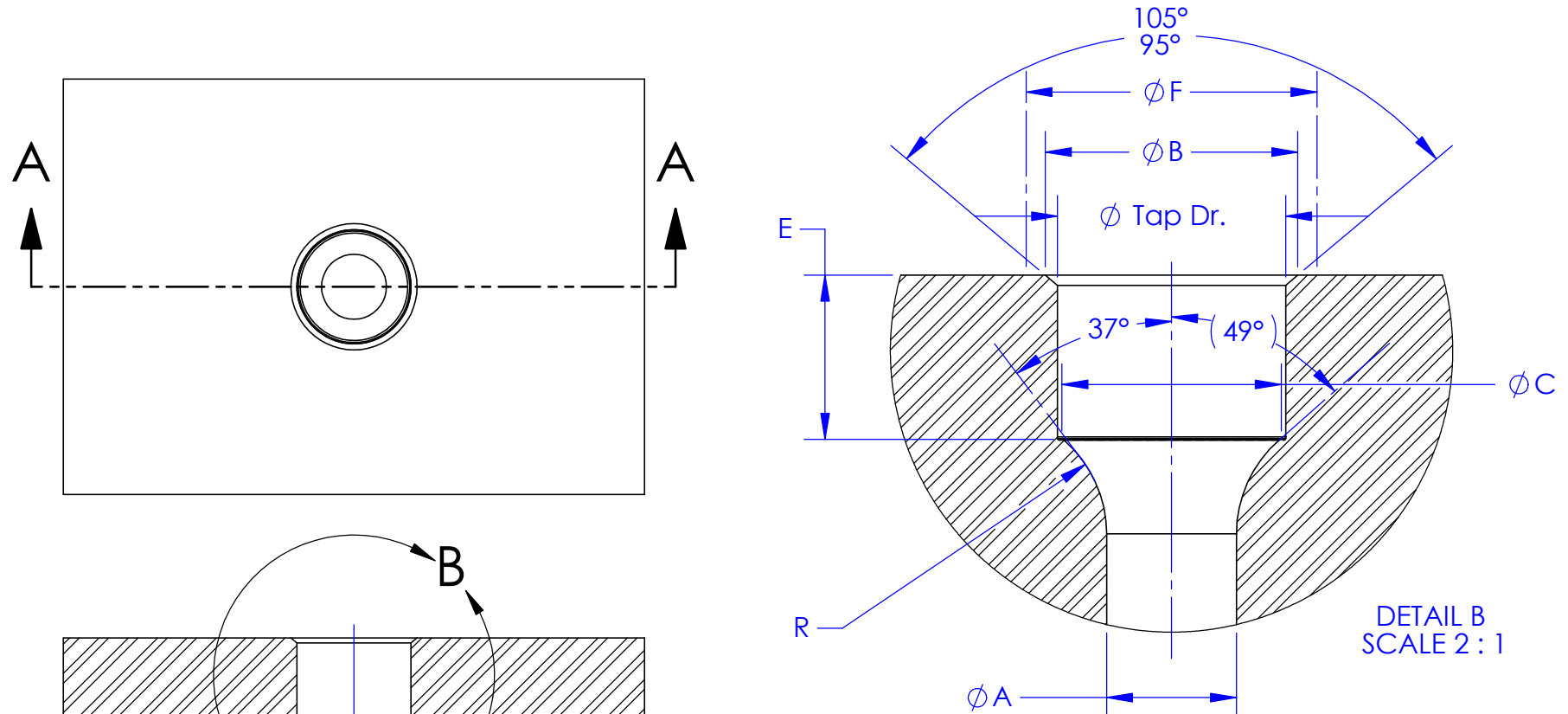

- NOTES:
1. Remove all hanging burrs & slivers.
 2. Maximum surface roughness (Ref. MIL-STD.10) 125 RHR unless otherwise specified.
 3. Pitch Dia. of thread, Dim. "C" & the 37° Angle measured and calculated as an Included angle shall be concentric within .008 TIR.
 4. 37° Surface shall be free from Burrs, longitudinal & spiral tool marks, and visible flat spots. Annular tool marks will be allowed to 63 RHR Maximum.
 5. Surface of Boss shall be spotfaced, Ø F.
 6. Rough machine Radius and 37° area to within .010 then use a modified radius cutter (See Above) for the final machining process. Polish radius. & seat area as needed.

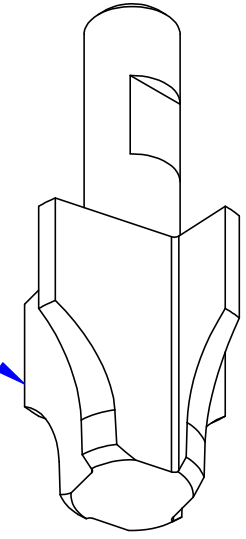
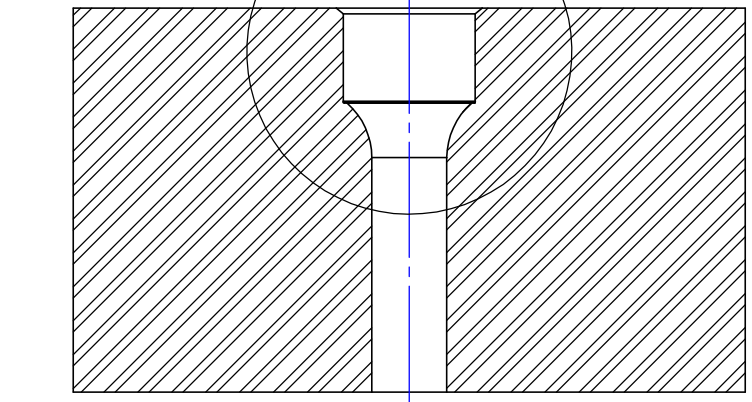

SECTION A-A

DRAWING SIZE B		SECO SEALS, INC. 1370 LOGAN AVE. UNIT K (714) 546-3478 sales@secoseals.com COSTA MESA, CA. 92626 www.secoseals.com	
MATL: See Note 1	FSCM:	FILE NAME: SECO-40	REV. A
TREATMENT: N/A	DESC.:		STANDARD:
MATL SIZE: N/A	TITLE:		CAGE CODE:
INCHES DIMENSIONS IN INCHES 3RD ANGLE PROJECTION		DATE DRAWN 4/8/2015	SCALE 1:1
DRAWN BY JL		CHECKED BY:	SHEET 1 of 1